

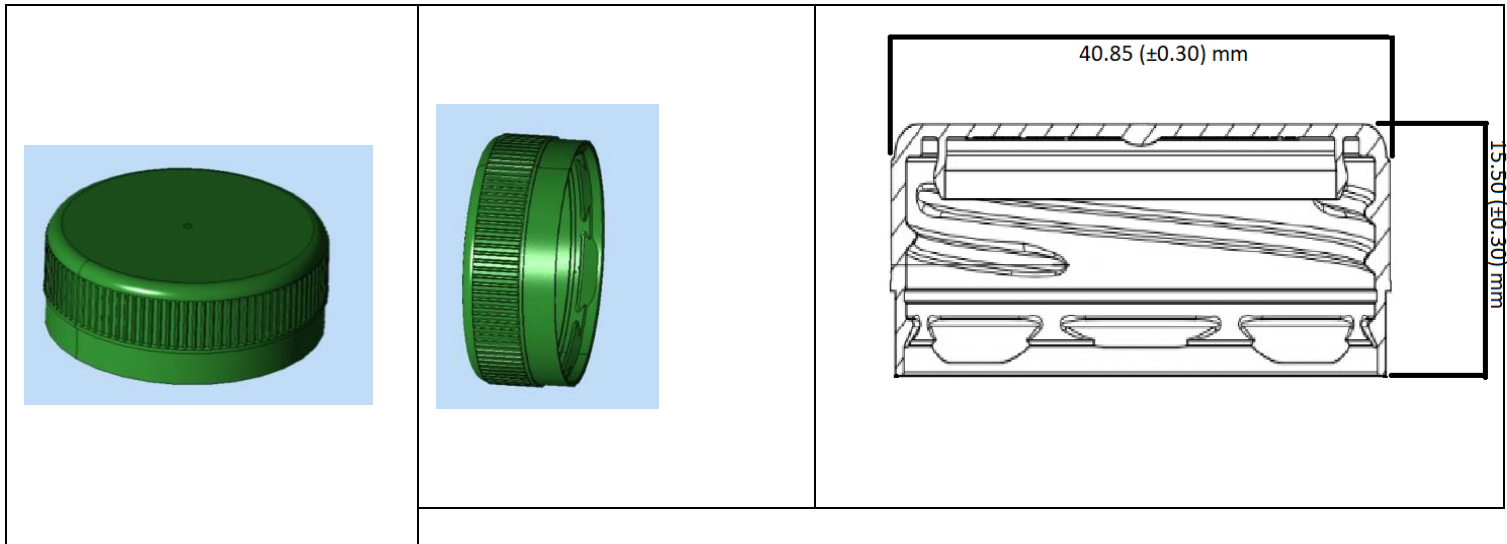

TECHNICAL DATA SHEET

38MM (3START) CAP



TECHNICAL INFORMATION

| | | |
|--------------------------------------|--------------------------------|-----------------|
| MATERIAL | HDPE | |
| NECK SIZE | 38mm | |
| WEIGHT | 3.10(±0.20) gms | |
| TAMPER EVIDENT BAND | Screw type | |
| NO OF KNURLS | 100 Knurls | |
| TOP LOAD REQUIREMENT IN FILLING LINE | 17-21Kg | |
| SEAL BREAKING STRENGTH | 55N-85N | |
| SPECIFICATIONS | OD with Knurls | 40.85(±0.30) mm |
| | Height | 15.50(±0.30) mm |
| | Plug OD | 33.90(±0.30) mm |
| USE | Milk, Juice, Water, Edible oil | |
| COLOR | Custom Colours Accepted | |

PACKING DETAILS

| | | |
|------------------------------|------------|----------|
| NO OF PCS IN A BOX | 4100pcs | |
| QUANTITY IN A 20ft CONTAINER | 1045500pcs | 255Boxes |
| QUANTITY IN A 40ft CONTAINER | 2849500pcs | 595Boxes |

CONTACT: indiasales@aglogroup.com/export@aglogroup.com
 WEBSITE: www.aglogroup.com