

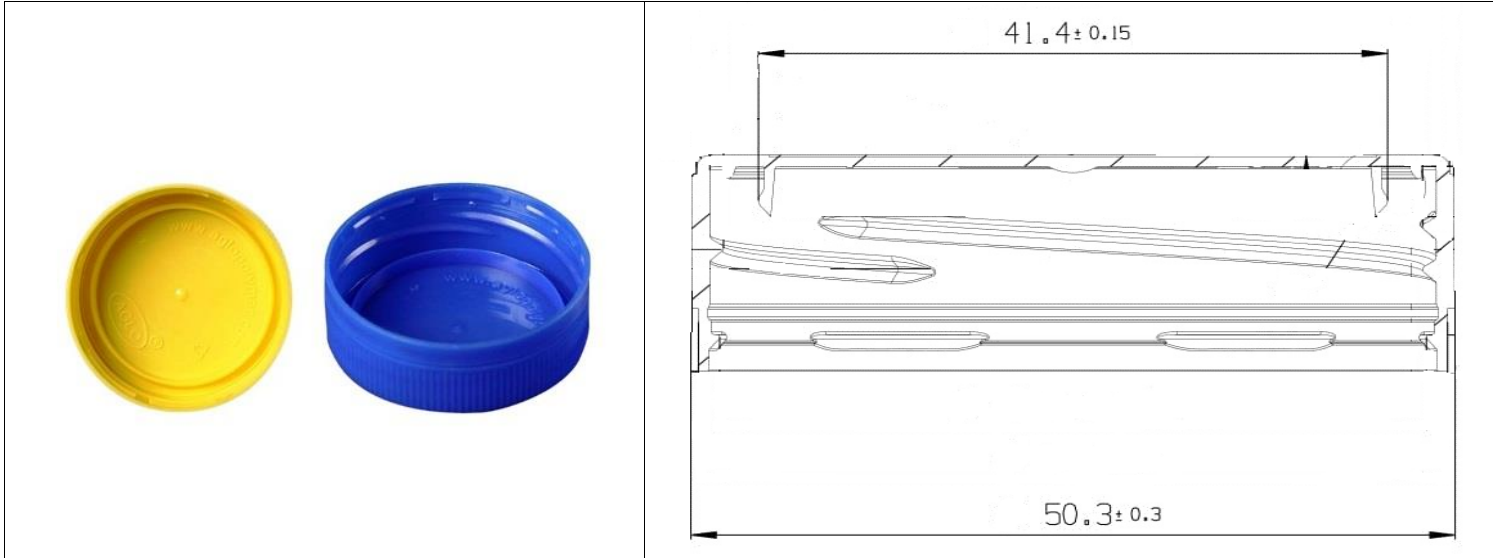

# TECHNICAL DATA SHEET

## 48mm SEAL CAP



### TECHNICAL INFORMATION

MATERIAL	HDPE
NECK SIZE	48/41 mm
WEIGHT	4.48(±0.20) gms
OD WITH KNURL	50.30(±0.50) mm
PLUG OD	41.45(±0.15) mm
HEIGHT	17.20(±0.50) mm
PLUG HEIGHT	4.40(±0.30) mm
NO OF KNURLS	120
TEMPER EVIDENT BAND	Screw Type
USE	5Ltr Mineral Water, Edible Oil and Others
COLOR	Custom colors accepted

### PACKING DETAILS

NO OF PCS IN A BOX	2600pcs	
QUANTITY IN A 20ft CONTAINER	663000pcs	255Boxes
QUANTITY IN A 40ft CONTAINER	1560000pcs	600Boxes